

TRANSPORTATION

1. PREPARATION FOR TRANSPORTATION

- 1) When transporting the machine, observe the various road rules, road transportation vehicle laws and vehicle limit ordinances, etc.
- 2) Select proper trailer after confirming the weight and dimension from chapter 7, Specification.
- 3) Check the whole route such as the road width, the height of bridge and limit of weight etc., which will be passed.
- 4) Get permission from the related authority if necessary.
- 5) Prepare suitable capacity of trailer to support the machine.

- 6) Prepare gangplank for safe loading referring to the below table and illustration.

A	B
1.0	3.65 ~ 3.85
1.1	4.00 ~ 4.25
1.2	4.35 ~ 4.60
1.3	4.75 ~ 5.00
1.4	5.10 ~ 5.40
1.5	5.50 ~ 5.75

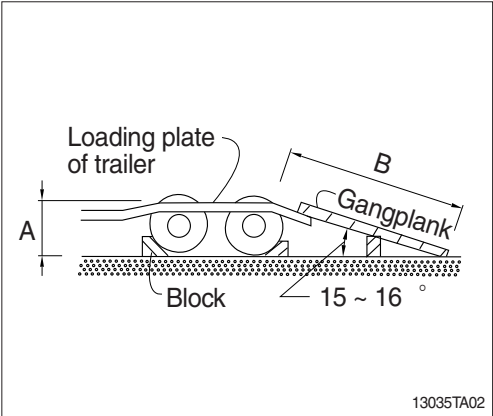
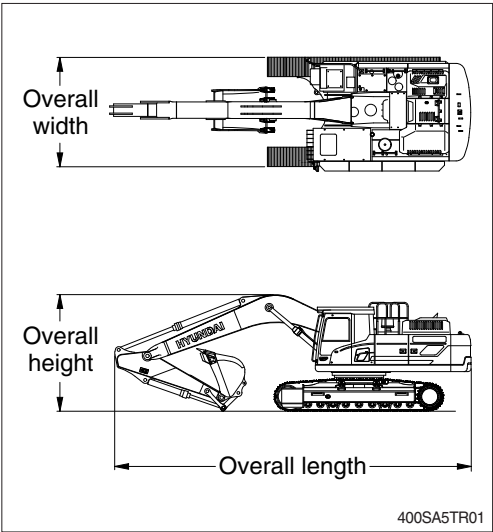

2. DIMENSION AND WEIGHT

1) HX400LT3

(1) Base machine

Mark	Description	Unit	Specification
L	Length	mm (ft-in)	5910 (19' 5")
H	Height	mm (ft-in)	3240 (10' 8")
W	Width	mm (ft-in)	3340 (10' 11")
Wt	Weight	kg (lb)	24030 (52980)

※ With 600 mm (24") triple grouser shoes.

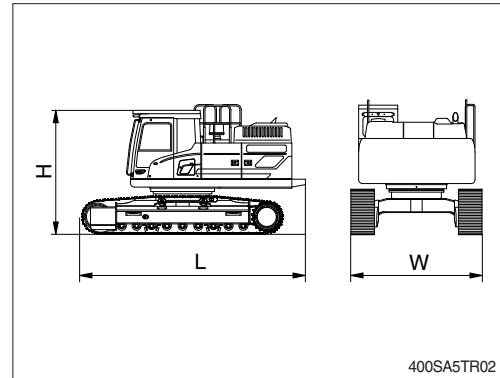

400SA5TR02

(2) Boom assembly

Mark	Description	Unit	Specification
L	Length	mm (ft-in)	6420 (21' 1")
H	Height	mm (ft-in)	1740 (5' 9")
W	Width	mm (ft-in)	825 (2' 8")
Wt	Weight	kg (lb)	3620 (7980)

※ 6.15 m (20' 2") boom with arm cylinder (including piping and pins).

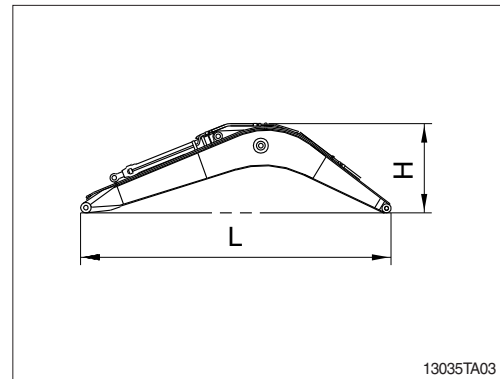

13035TA03

Boom assembly

Mark	Description	Unit	Specification
L	Length	mm (ft-in)	6770 (22' 3")
H	Height	mm (ft-in)	1635 (5' 4")
W	Width	mm (ft-in)	825 (2' 8")
Wt	Weight	kg (lb)	3750 (8270)

※ 6.50 m (22' 4") boom with arm cylinder (including piping and pins).

(3) Arm assembly

Mark	Description	Unit	Specification
L	Length	mm (ft-in)	3700 (12' 2")
H	Height	mm (ft-in)	1195 (3' 11")
W	Width	mm (ft-in)	430 (1' 5")
Wt	Weight	kg (lb)	1950 (4300)

※ 2.55 m (8' 4") arm with bucket cylinder (including linkage and pins).

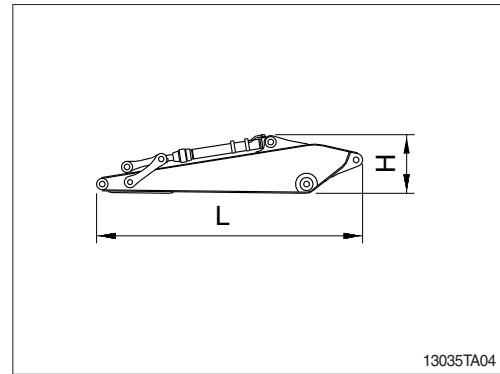

Arm assembly

Mark	Description	Unit	Specification
L	Length	mm (ft-in)	3950 (13' 0")
H	Height	mm (ft-in)	1195 (3' 11")
W	Width	mm (ft-in)	430 (1' 5")
Wt	Weight	kg (lb)	2000 (4410)

※ 2.80 m (9' 2") arm with bucket cylinder (including linkage and pins).

Arm assembly

Mark	Description	Unit	Specification
L	Length	mm (ft-in)	4410 (16' 6")
H	Height	mm (ft-in)	1200 (3' 11")
W	Width	mm (ft-in)	430 (1' 5")
Wt	Weight	kg (lb)	2080 (4590)

※ 3.20 m (10' 6") arm with bucket cylinder (including linkage and pins).

Arm assembly

Mark	Description	Unit	Specification
L	Length	mm (ft-in)	5095 (16' 9")
H	Height	mm (ft-in)	1000 (3' 3")
W	Width	mm (ft-in)	430 (1' 5")
Wt	Weight	kg (lb)	2190 (4830)

※ 3.90 m (12' 10") arm with bucket cylinder (including linkage and pins).

(4) Bucket assembly

Mark	Description	Unit	Specification
L	Length	mm (ft-in)	1910 (6' 3")
H	Height	mm (ft-in)	1290 (4' 3")
W	Width	mm (ft-in)	1480 (4' 10")
Wt	Weight	kg (lb)	1500 (3310)

※ 1.62 m³ (2.12 yd³) SAE heaped bucket (including tooth and side cutters).

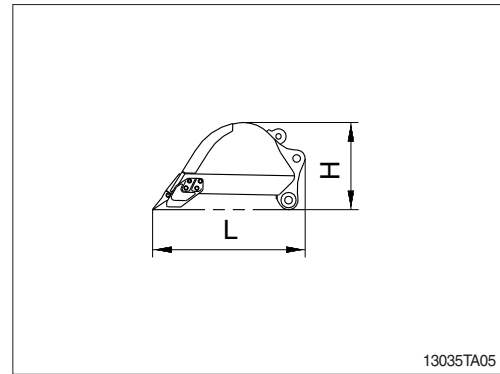

(5) Boom cylinder

Mark	Description	Unit	Specification
L	Length	mm (ft-in)	2305 (7' 7")
H	Height	mm (ft-in)	291 (0' 11")
W	Width	mm (ft-in)	455 (1' 6")
Wt	Weight	kg (lb)	357 (790)

※ Including piping.

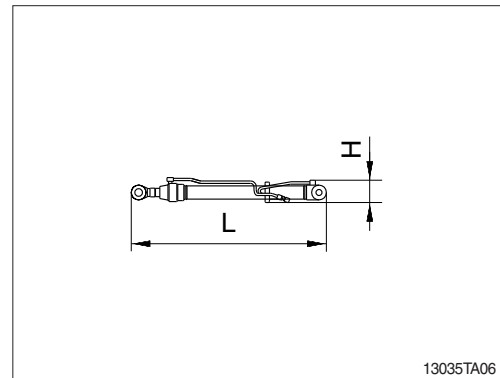

(6) Cab assembly

Mark	Description	Unit	Specification
L	Length	mm (ft-in)	1950 (6' 5") [2055 (6' 9")]
H	Height	mm (ft-in)	1780 (5' 10") [1780 (5' 10")]
W	Width	mm (ft-in)	1104 (3' 7") [1103 (3' 7")]
Wt	Weight	kg (lb)	555 (1220) [648 (1430)]

[] : with FOG GUARD

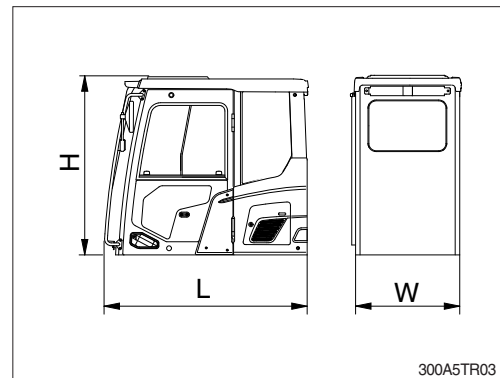

(7) Counterweight

Mark	Description	Unit	Specification
L	Length	mm (ft-in)	2980 (9' 9")
H	Height	mm (ft-in)	1245 (4' 1")
W	Width	mm (ft-in)	640 (2' 1")
Wt	Weight	kg (lb)	6200 (13670)
			8100 (17860)
			7000 (15430)
			7500 (16530)

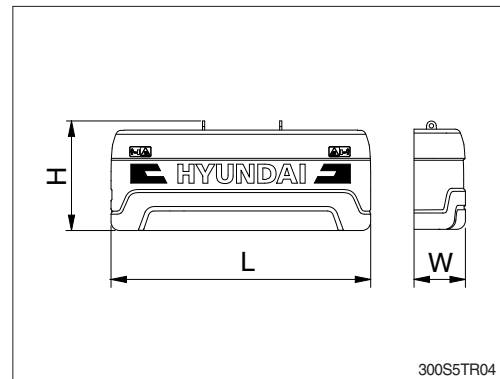

3. LOADING THE MACHINE

- 1) Load and unload the machine on flat ground.
- 2) Use the gangplank with sufficient length, width, thickness and gradient.
- 3) Place the swing lock/fine switch to the LOCK position (if equipped) before fixing the machine at the bed of trailer and confirm if the machine is parallel to the bed of trailer.

Keep the travel motor in the rear when loading and in the front when unloading.

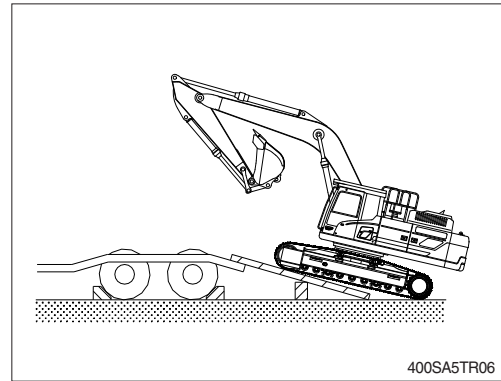

- 4) Do the following after loading the machine to the trailer.

- (1) Stop loading when the machine is located horizontally with the rear wheel of trailer.

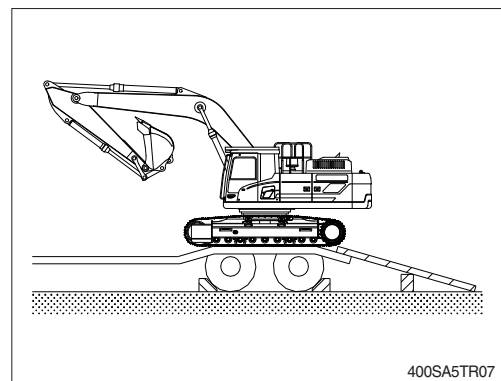

- (2) Place the swing lock/fine switch to the LOCK position (if equipped) after swinging the machine 180°.

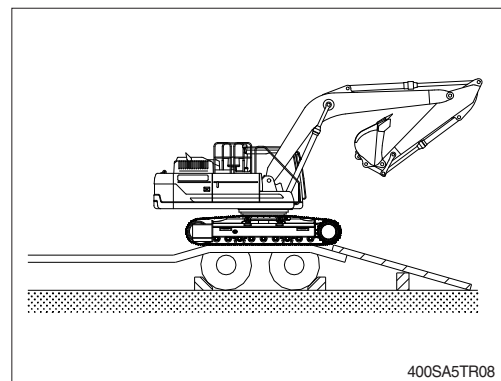

- (3) Lower the working equipment gently after the location is determined.
- ※ Place rectangular timber under the bucket cylinder to prevent the damage of it during transportation.
 - ▲ Be sure to keep the travel speed switch on the LOW (turtle mark) while loading and unloading the machine.
 - ▲ Avoid using the working equipment for loading and unloading as it will be very dangerous.
 - ▲ Do not operate any other device when loading.
 - ▲ Be careful as to the boundaries of loading plate or trailer as the balance of machine will abruptly change.

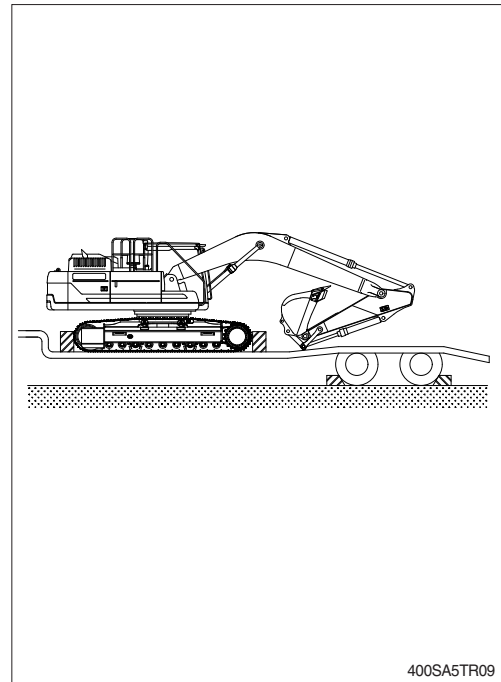

4. FIXING THE MACHINE

- 1) Lower down the working device on the loading plate of trailer.
- 2) Keep the safety knob in the LOCK position.
- 3) Turn OFF all the switches and remove the key.

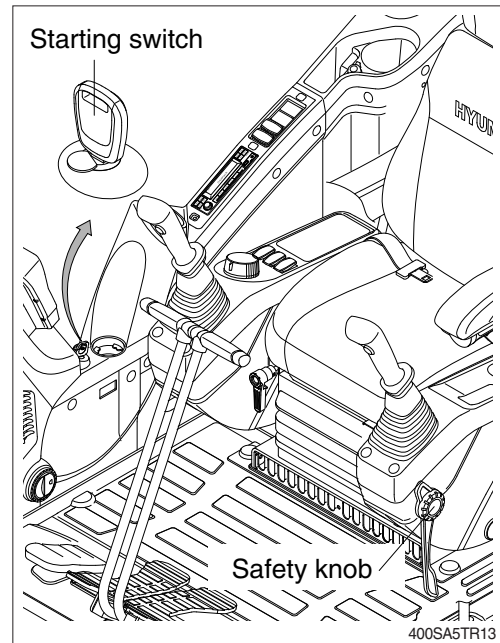

- 4) Secure all locks.

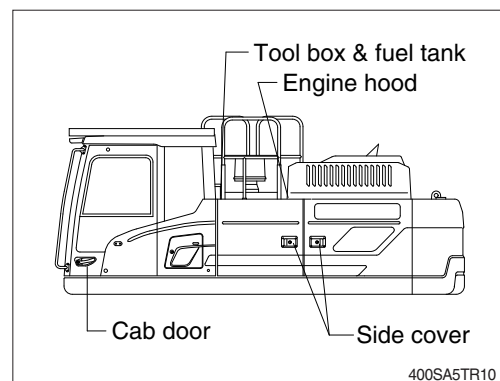

- 5) Place timbers behind the tracks, secure the machine to trailer with chains or straps which are in good condition and approved for the weight which they will be securing, to prevent the machine from moving in any direction.

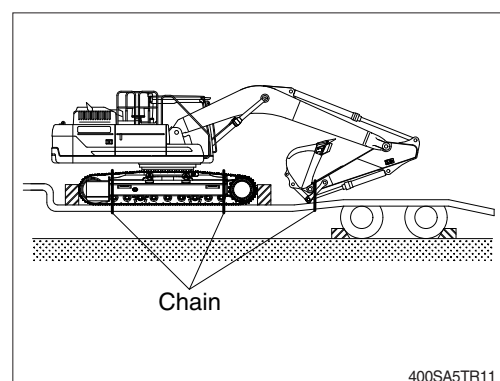

5. LOADING AND UNLOADING BY CRANE

▲ The wrong hoisting method or installation of lifting device can cause serious injury, death, or damage to the machine.

- 1) Check the weight, length, width and height of the machine referring to chapter 7, Specification when you are going to hoist the machine.
- 2) Use approved lifting device and ensure distance between lifting device and machine to avoid contact between the two.
- ※ **Remove any parts (footboard, etc) that may be damaged by contact with the lifting device before lifting.**
- 3) Place rubber plates at lifting points to avoid any damage to the machine.
- 4) Place crane in the proper place.
- 5) Install approved lifting device as shown in the illustration.
- 6) Use stay between the wire rope and the machine to prevent damage to the rope or machine. Set the lifting angle of the wire rope to $30^{\circ}\sim 40^{\circ}$.
- 7) After the machine comes off the ground, check the hook condition and the lifting posture, and then lift slowly.

▲ Ensure that lifting device is free from any damage and is approved for the weight being lifted and supported.

▲ Place the safety knob to LOCK position to prevent the machine from moving when hoisting the machine.

▲ Do not load abruptly.

▲ Keep area clear of any and all personnel.

